



□ 公开
■ 非公开

Emergency rescue card FOTON LDT EV

Foton International Trade Co., Ltd, Beijing

NOV. 2022

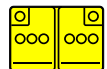

24V Battery



HV Battery



HV MSD/Disconnect



HV wires/components

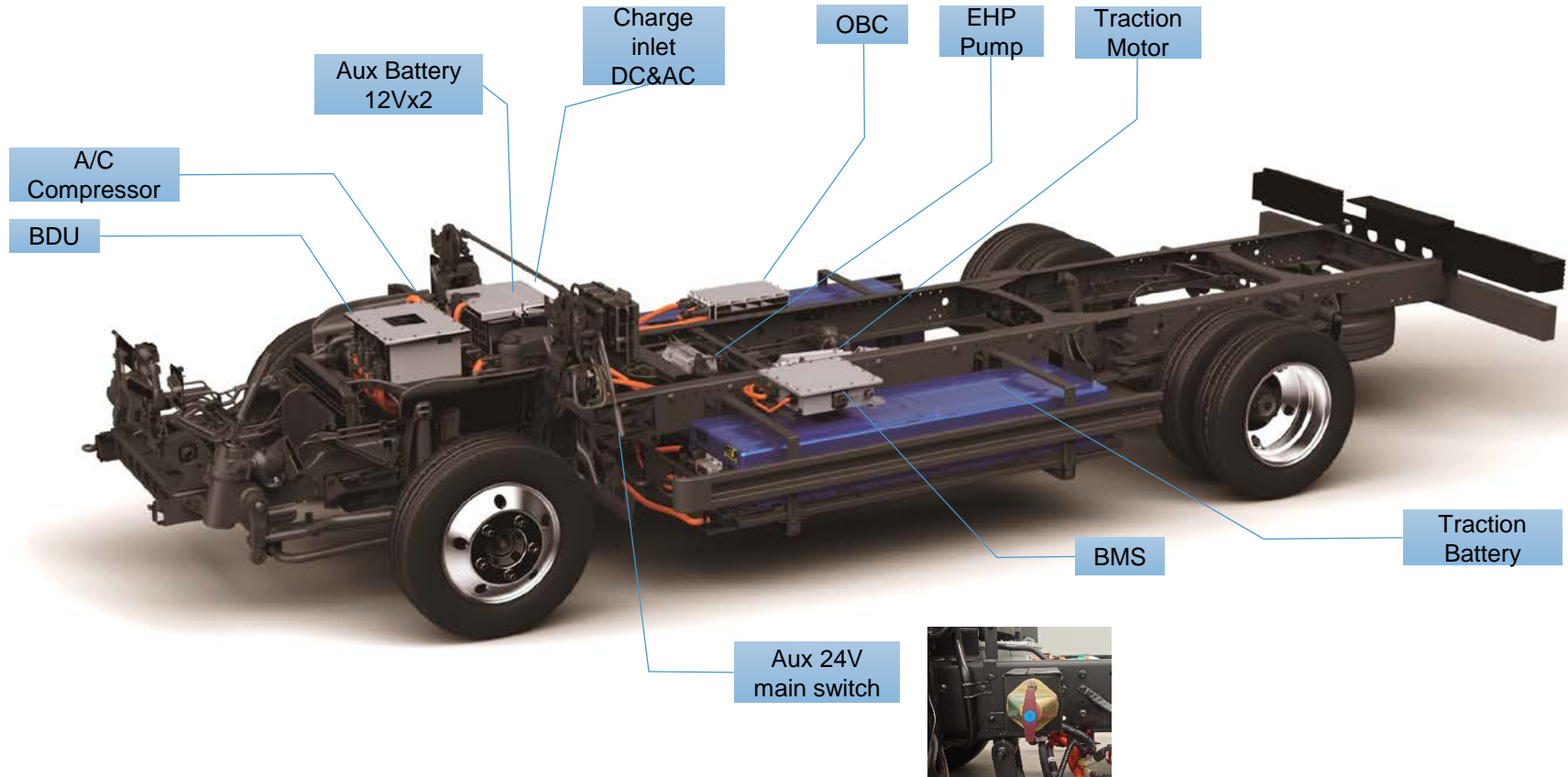





Battery MSD with FUSE

Battery MSD without FUSE

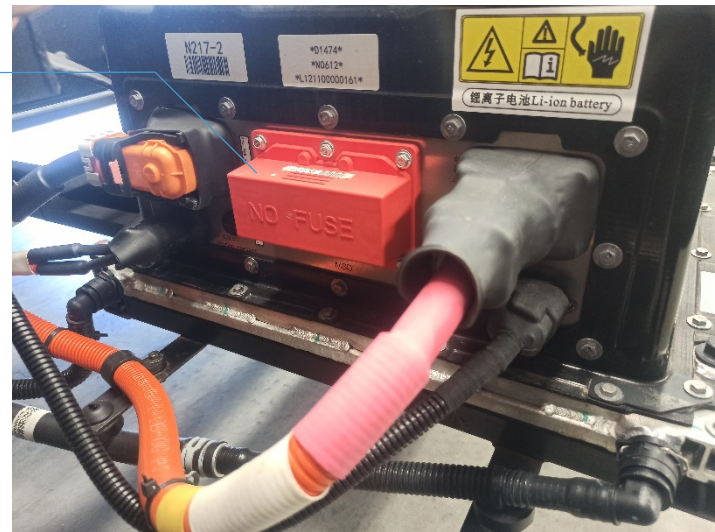

BDU MSD with FUSE

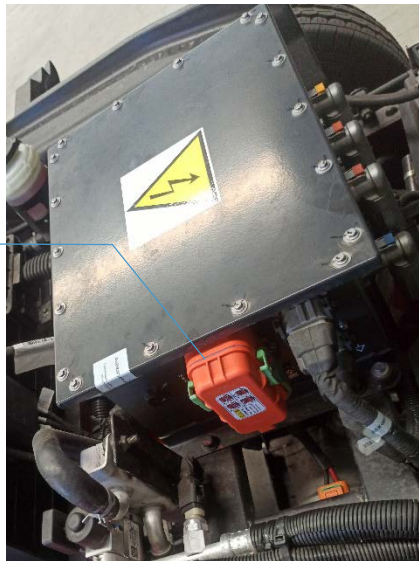

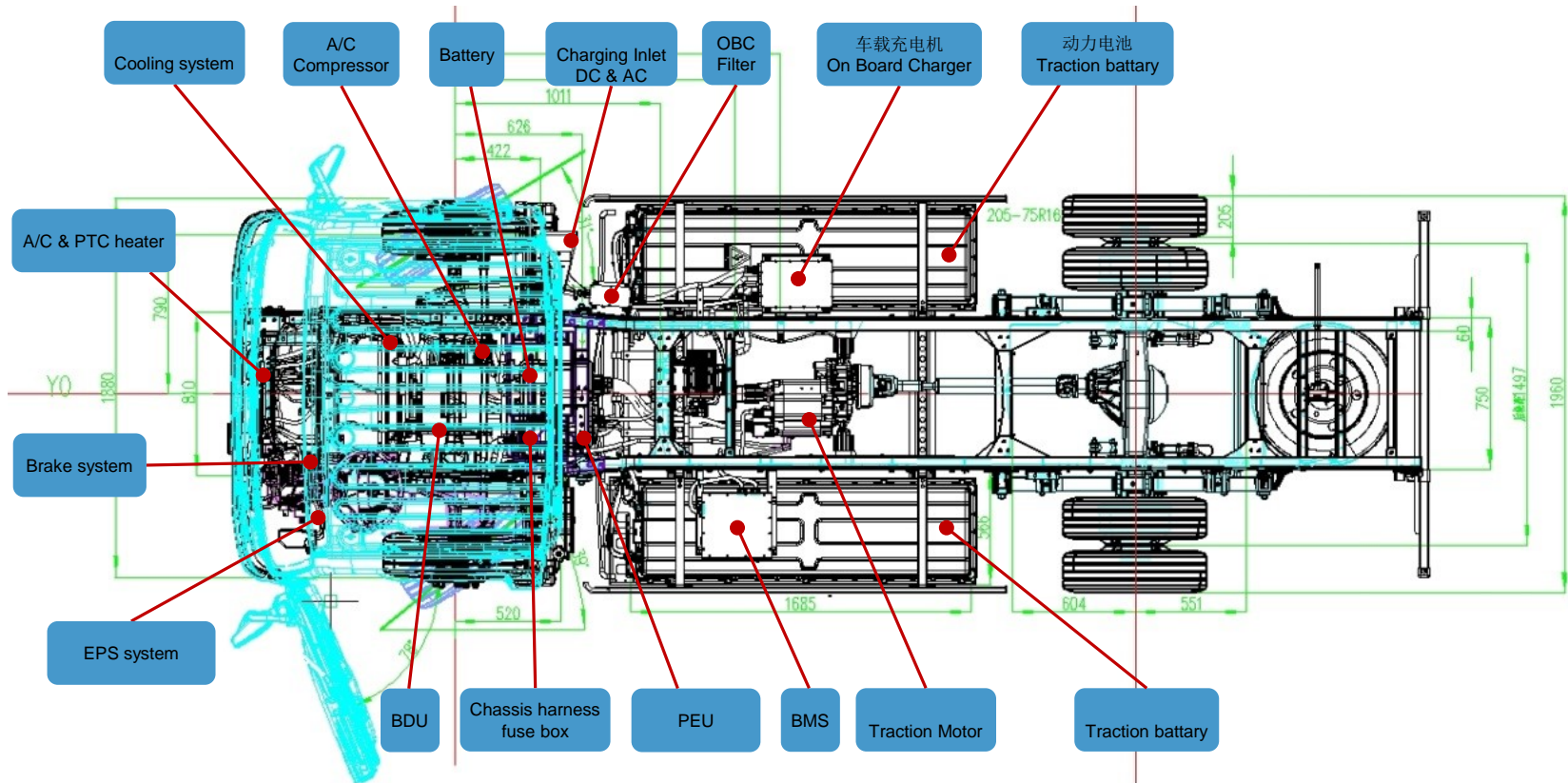

Before doing anything to the HV parts or systems, the first step is to cut off the HV power.



If we will operate on the devices except for the Battery system(Battery pack & BDU & Battery heating circuit), we need to disconnect the one MSD on BDU, so that the power will be cut off.

MSD: Manual service Device

Which can cut HV circuit directly by disconnection



Vehicle basic parameter information

trademark		
Factory logo		
car model	BJ5045XXYEV	
Outside dimensions	Length (A)/mm	5995
	Width (B)/mm	2240
	Height (C)/mm	3160
Rated number of passengers: 3		
The maximum allowable total mass/kg: 6000		

Vehicle photo:
(Due to the large amount of market resources, the actual vehicle is slightly different from the picture, please refer to the actual vehicle)

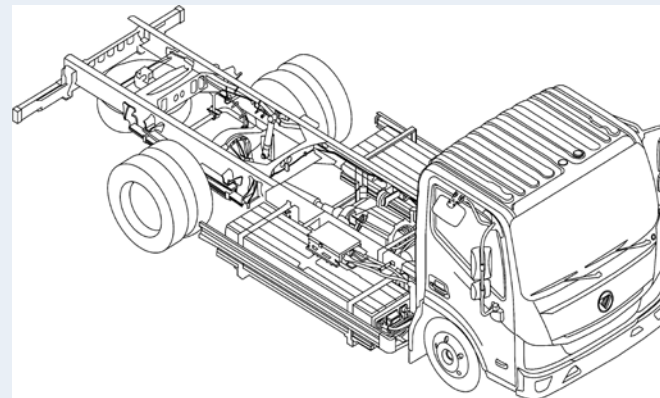

car model	BJ5045XXYE8	
battery cell	type	high energy applications
	Rated voltage/V	3.22
Traction battery system	Rated capacity/Ah	150
	Number of power battery packs/piece	1
	Power battery size/mm	1718×518×243
	Rated voltage/V	540.96
	Rated capacity/Ah	150
	Battery system mass/kg	554
Fuel type	pure electric	

Schematic diagram of the location of the power system

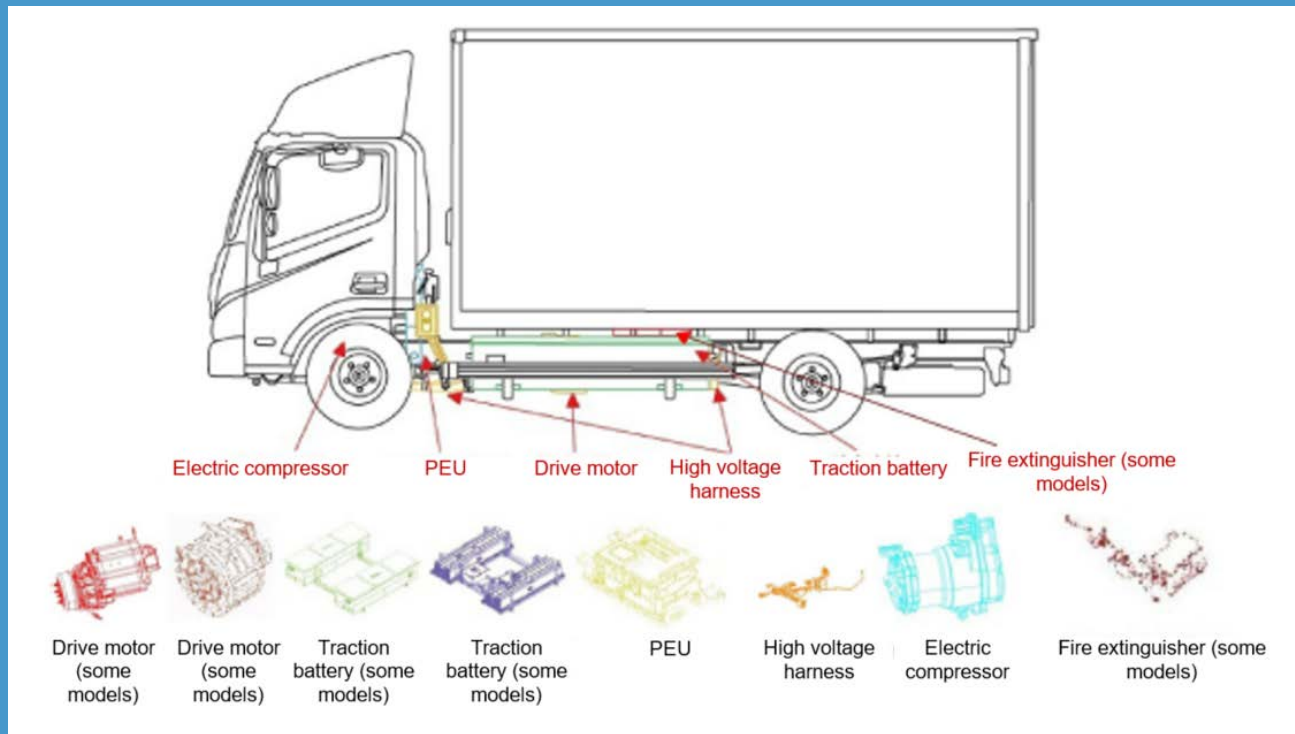

Schematic diagram of the location of the power system

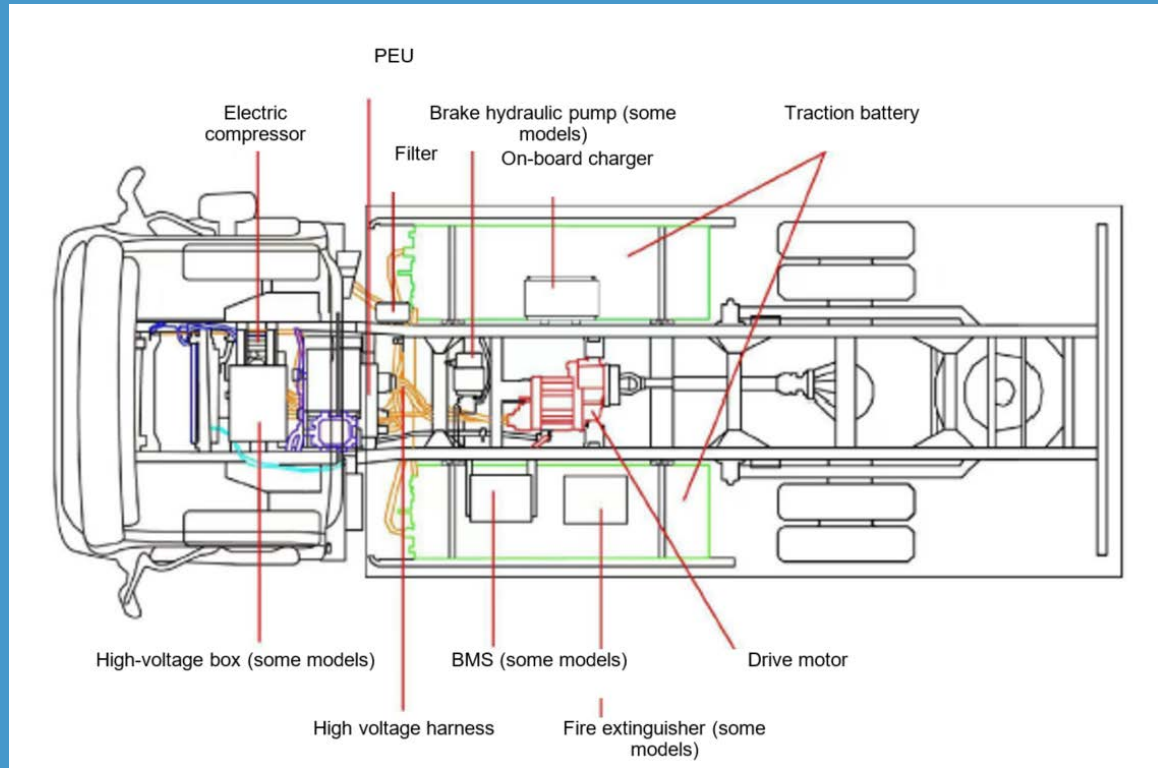

THANKS

